

Driver "Duo" 1-10V / Push / DALI dimmable

Art. nr. 490.26.40

Independent LED driver

DIP-switch settings:

Output current is set using dip-switches.
Always make sure that dip-switch setting corresponds to the required output current.
Dip-switch settings can be found printed on the driver.
Incorrect settings may damage the LED

Suitable for:

Atlas 700: max. 700mA
FlatLED: max. 350mA
Titan: max. 350mA
Vesto 350: max. 350mA
Vesto 500: max. 500mA
Tekton 45: max. 350mA
Tekton 65: max. 350mA

Installation information:

Wire section 0.5-2.5mm²
Max 15m distance from driver to LED

Max. nr. of drivers on single circuit:

MCB 10A type B: 9
MCB 16A type B: 15
MCB 20A type B: 18
MCB 25A type B: 22

MCB 10A type C: 15
MCB 16A type C: 24
MCB 20A type C: 30
MCB 25A type C: 38

Inrush current: 20A
Inrush current 1/2 value time (Twidth): 400µs
Power factor (λ max): 0.95

DALI connection:

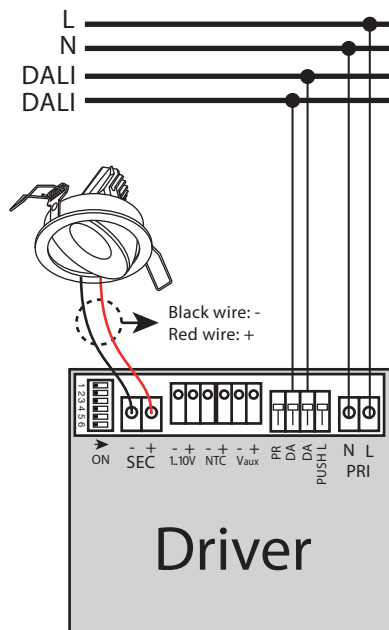

1-10V connection:

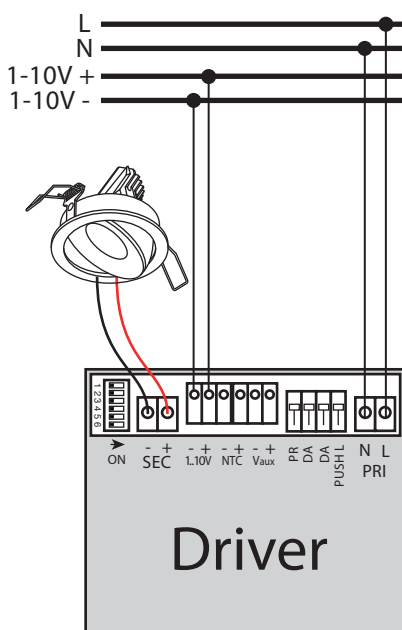

Connecting multiple LEDs:

Atlas 700: max. 2pcs/driver
FlatLED: max. 2pcs/driver
Titan: max. 2pcs/driver
Vesto 350/500 single: max. 7pcs/driver
Vesto 350/500 double: max. 3pcs/driver
Vesto 350/500 triple: max. 2pcs/driver
Vesto 350/500 quadro: max. 1pc/driver
Tekton 45: max. 2pcs/driver
Tekton 65: max. 2pcs/driver
Always connect **IN SERIES!!!!**

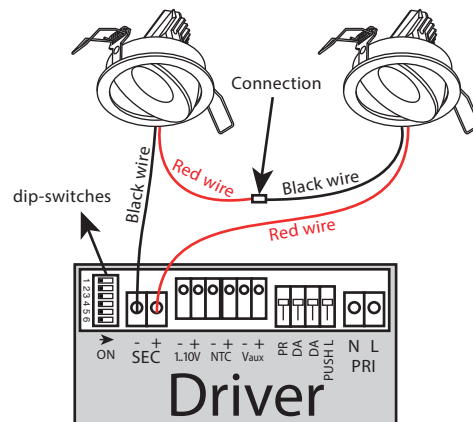

Dimensions: 124x79x22mm

Push connection:



Push operation:

Short push: ON / OFF
Long push: increase / decrease light intensity

Other info:

For optimal functioning, it is recommended to use a max. of 5 Drivers on 1 push button.
Max. cable length from push button to driver is 15m.
It is recommended to keep the push button wires separate from 230V wires (this may cause interference)
Only to be used connected directly to a standard NO (normally open) push button.
Push buttons must always be installed on the same electrical circuit as the driver.
Only use normally open push buttons without additional circuitry (warning lights, relay units, etc.)

Synchronising:

When adding new LEDs or when LEDs are showing asynchronous behavior, it is possible to reset the system.

Method of resynchronisation:

- 1- Drivers must be on.
- 2- press push switch for more than 1 second
- 3- short push must follow immediately after long push

Only to be installed by a qualified electrician.

Doxis cannot be held responsible for damage caused by incorrect settings or incorrect installation.

Document updated 12/12/2019. This document is subject to change.